

PFA SERIES MODELS

FULLY AUTOMATIC VENTLESS COUNTERTOP DEEP FRYER

Advanced by Design



- FULLY AUTOMATED COOKING SYSTEM
- FRONT LOADING/ FRONT DISPENSING
- SMALL FOOTPRINT
- PROGRAMMABLE PRESETS
- ODORLESS
- INTEGRAL VENTLESS HOOD
- INTEGRAL FIRE SUPPRESSION
- LARGEST OUTPUT
- EASY TO CLEAN
- FULLY ENCLOSED
- INTEGRAL INFRA-RED, CERAMIC HEAT LAMP AND OIL DRAINAGE KIT
- NON-STICK BASKET



PERFECT FRY COMPANY LLC
42 Allen Martin Drive
Essex Junction, VT 05452
www.PerfectFry.com

GENERAL INFORMATION:
Phone: 1-802-658-6600
Fax: 1-802-864-0183
Email: profits@perfectfry.com
83717 Rev A (1/2020)



The Benchmark in Ventless Deep Frying

CLEARANCES

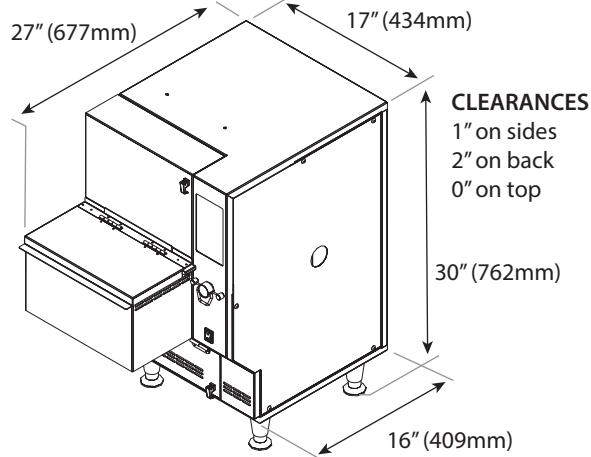

AIRFLOW DIAGRAM

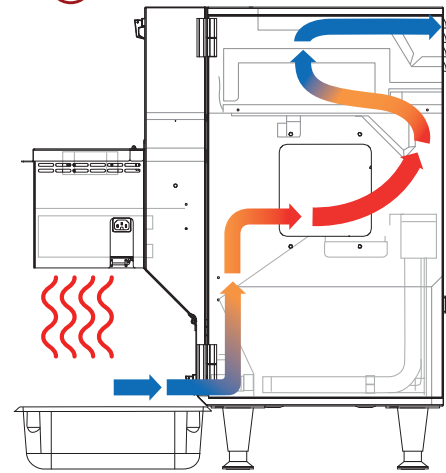

SPECIFICATIONS TABLE

MODEL	PFA720	PFA570	PFA570	PFA375
ORDER NUMBER	Determined by options, please call 1-802-658-6600			
POWER SUPPLY (volts) ¹	380/220	240	208	240
CURRENT (amps)*	9.9	25.4	28.8	18
CORD OPTION	10/3 powercord 6-30 plug	8/3 powercord 6-50 plug	8/3 powercord 6-50 plug	10/3 powercord 6-30 plug
POWER (kilowatts)	6.5	6.1	6	4.2
CAPACITY (lbs/hr)‡**	90	70	70	50

¹other voltages and/or wattages may be available, please contact 1-603-225-6684

ADVANCED ELECTRONIC CAPABILITIES

- Cook Time Sensitivity (CTS)[™]
- Stand-by Mode
- Preset Counters
- Dual Load Cook Cycle
- Food Type Sensitivity (FTS)[™]
- Hold Time Monitor

RAPIDFRY[™] TECHNOLOGY

RapidFry[™] technology allows the operator to pre-load food into the drawer while other food product is frying in the cooking oil. The second load of food will automatically begin cooking once the first cook cycle is completed.

GENERAL SPECIFICATIONS

*For use on an individual branch circuit. This fryer must be properly connected to a grounded, dedicated phase circuit according to local installation standards and codes.

** Using 11/2 minute fast fries.

Heat Lamp (see below)	Integral On All Units
Phase	3
Cycles	50/60 Hz
Weight	125 lbs (57 kg) 155 lbs (70kg)
Shipping Weight	Depth 24" (610 mm)
Shipping Dimensions	Width 29" (737mm)
	Height 36" (914 mm)
Shipping Cube	9.52 ft ³ (.271 m ³) 2.75
Oil Capacity	US Gallons (11 L)
Product Capacity	3 lbs per load
	****Locking Cabinet Option also Available

ACCESSORIES

Heat Lamp - (Part number determined by country, please call 1-603-225-6684)

2 amps
 240 volt
 500 watts
 Ordered Separately

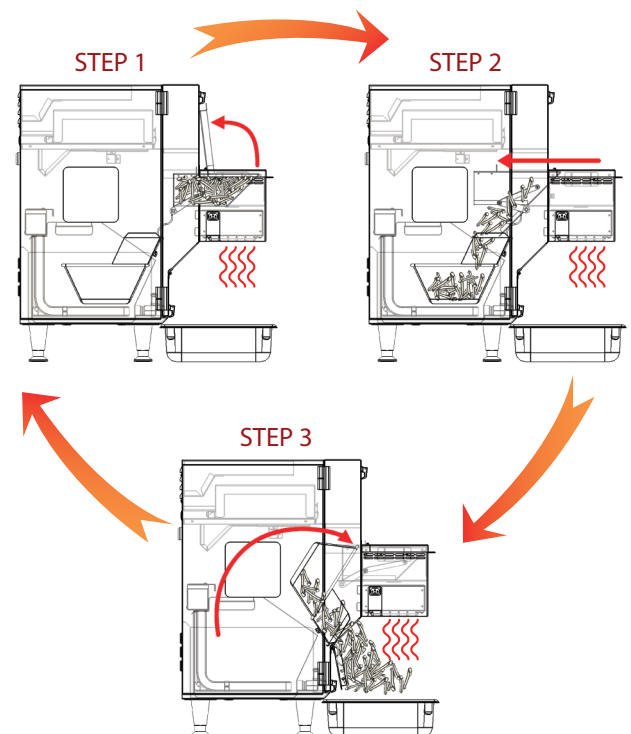

SPECIFICATIONS SUBJECT TO CHANGE WITHOUT NOTICE
 © 2020 Perfect Fry Company LLC. Printed in USA
 83717 Rev A (1/2020)

